



SELEX GALILEO

A Finmeccanica Company



FLIR 111 - HELICOPTER NAVIGATION FLIR FORWARD LOOKING INFRARED

The FLIR 111 is a state-of-the-art, high performance, compact, lightweight navigation Forward Looking InfraRed (FLIR) for utility and attack helicopters.

From a solid background in Electro-Optics (EO) and InfraRed (IR) applications and exploiting the new technologies, the FLIR 111 features:

- High level of integration
- Low power consumption
- Simple mechanical interface
- Standard electrical interface
- Minimal number of interconnections.

The FLIR 111 makes use of a second generation thermal camera mounted onto a two-axis steering platform. The video image, generated by the thermal camera, presented on the pilot's Helmet Mounted Display (HMD), allows the crew to navigate a 'map of the earth' at night and in adverse weather conditions.

The FLIR 111 has been qualified for NH90/TTH and Tiger helicopters.

It is jointly produced by SELEX Galileo (Prime Contractor), Hensoldt Systemtechnik GmbH (Zeiss Group) and AEG-Infrarot-Module.

FLIR 111 - Helicopter Navigation FLIR Forward Looking InfraRed

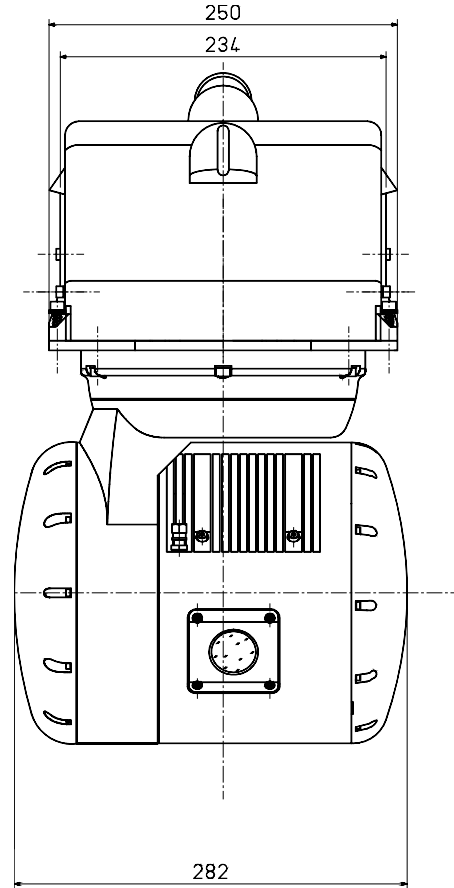
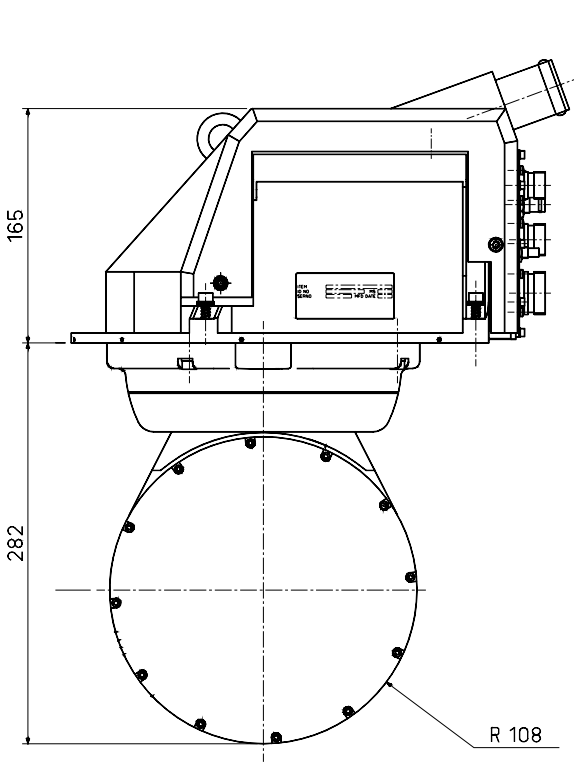

TECHNICAL CHARACTERISTICS

Platform

Field of Regard	$\pm 130^\circ$ (azimuth) $+ 45^\circ \div - 70^\circ$ (elevation)
Angular Speed	140°/sec (azimuth) 150°/sec (elevation)
Angular Acceleration	1000°/sec ² (azimuth) 1140°/sec ² (elevation)
Position Resolution	0,2 m Rad.

Thermal Camera

Spectral Range	7.5 - 10.5 mm
Detector	288 x 4 TDI linear array
Field of View	30° x 40°
Cooling	Linear split stirling cooler
NETD	< 0.1 K°

System

Power Consumption	150 W typical
Weight	$\cong 20$ Kg
Dimensions	See image



FLIR 111 on a Tiger helicopter

For more information please email sales.marketing@selexgalileo.com

SELEX Galileo S.p.A. - A Finmeccanica Company

Via A. Einstein, 35 - 50013 Campi Bisenzio (FI) - Italy

This publication is issued to provide outline information only and is supplied without liability for errors or omissions. No part of it may be reproduced or used unless authorized in writing.

We reserve the right to modify or revise all or part of this document without notice.

2010 © Copyright SELEX Galileo.

www.selexgalileo.com

SELEXGALILEO\IT\Dsh-127\0110