

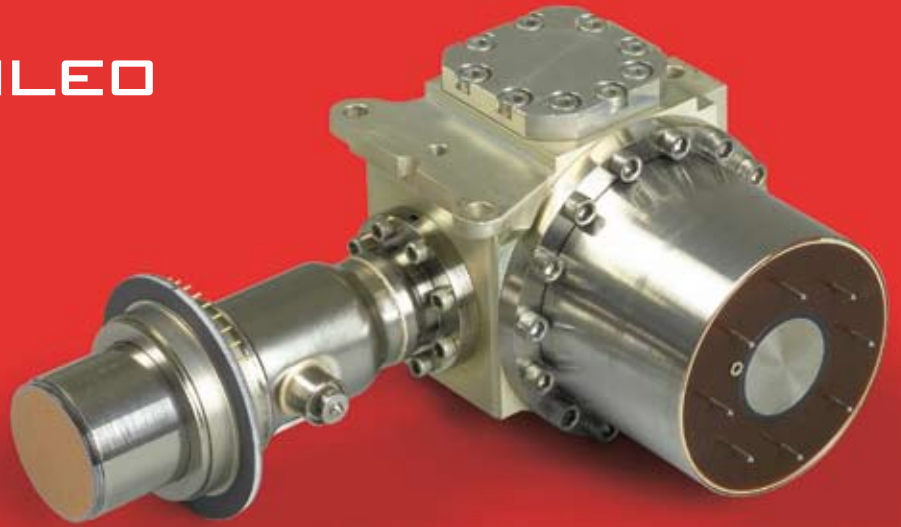

# SELEX GALILEO

A Finmeccanica Company



## SWAN DUAL MODE INFRARED DETECTOR

SELEX Galileo designs, develops and manufactures Infrared (IR) detectors at its dedicated facility in Southampton, UK. With a reputation for providing customers with the best in high performance and cost-effective technology for IR camera systems, SELEX Galileo offers a unique level of expertise.

The Swan dual mode Infrared (IR) detector is a unique product offering a variety of imaging modes within one compact lightweight 320 x 256 Mercury Cadmium Telluride (MCT) Integrated Detector Cooler Assembly (IDCA). The Swan dual mode IR detector can be used for laser gated imaging at the eye-safe 1.5 $\mu$ m wavelength, or high performance passive thermal imaging in the 3–4.2 $\mu$ m waveband. The Swan detector can also be used for passive or solar imaging in the short waveband. This combination of imaging modes allows electro-optic systems to be designed with much lower costs, size and weight.

Using the SELEX Galileo MCT process, the Swan dual mode detector provides the highest environmental integrity along with the superior performance of focal plane detectors.

### MAIN FEATURES

- Snapshot operation
- Simple to operate
- Small element pitch enables miniaturisation of the Dewar assembly and optics
- Short Wave and Medium Wave response
- High electro-optic performance with low crosstalk and automatic anti-blooming at the pixel level
- Switchable on a frame by frame basis from active to passive imaging
- Sensitivity in active laser gated imaging mode as low as 10 photons
- Enables a new range of miniaturised electro-optic systems with active, passive and solar imaging
- Highest Performing Active Imaging
- Combination of wave bands provides improved DRI over 1st & 2nd Gen. systems
- Mode switching to enhance performance in all imaging conditions

### KEY BENEFITS

- Low cost
- Light weight
- Compact
- Multi-function operation



Detector manufacture and test facilities

**TECHNICAL SPECIFICATIONS**

**Format**

Array	320 x 256 pixels
Pixel Pitch	24µm
Active Area	7.68 x 6.14

**Typical Performance**

Median NEPh	<30 photons
NETD (median) MW	16mK
Pixel Operability	>99%

**Interface Parameters**

Modes	Snapshot
Configuration Control	Single serial interface
Output Voltage Range	3V
Charge Capacity	8.8 x 10 <sup>6</sup> electrons
Number of Outputs	4
Pixel Rate	Up to 5MHz per output
Array Operating Temperature	90K nominal
Nominal Operating Voltage	7V
Minimum Pins for Operation	16
Number of Input Clocks	1
Window Material	Silicon
Window Thickness	1.25mm
Cold Filter Material	None

**IDCA 6W**

Weight	350g
Power Consumption	6W steady state
Cooling Engine	Rotary Stirling engine
Operating Temperature Range	-40 °C to +70 °C

**IDCA 8W**

Weight	500g
Power Consumption	8W steady state
Cooling Engine	Rotary Stirling engine
Operating Temperature Range	-40 °C to +70 °C

**IDCA 6W**

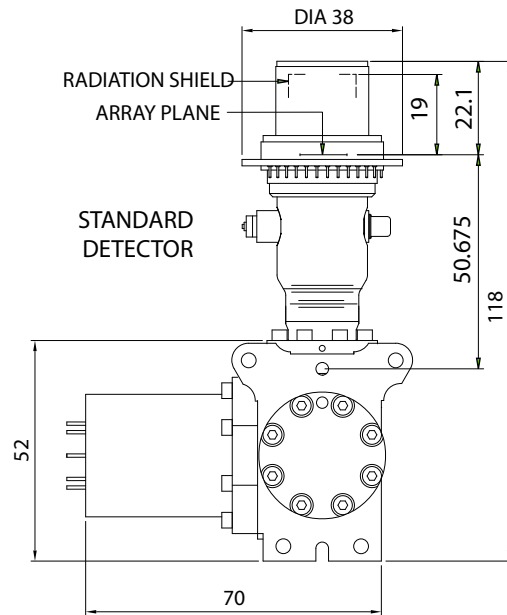

**IDCA 8W**

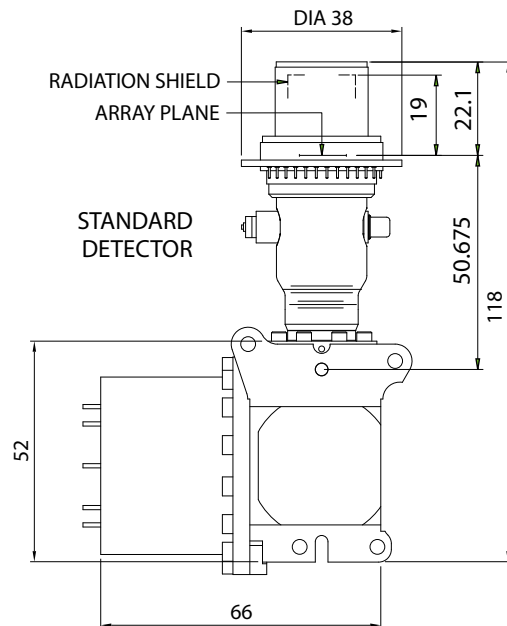

All dimensions in millimetres

For more information please email [Infrared.sales@selexgalileo.com](mailto:Infrared.sales@selexgalileo.com)

**SELEX Galileo Ltd**, A Finmeccanica Company

Millbrook Industrial Estate, Southampton, Hampshire, SO15 0LG, United Kingdom, Tel: +44 (0) 23 8070 2300, Fax: +44 (0) 23 8031 6777

This publication is issued to provide outline information only and is supplied without liability for errors or omissions. No part of it may be reproduced or used unless authorised in writing.

We reserve the right to modify or revise all or part of this document without notice.

2010 © Copyright SELEX Galileo Ltd

[www.selexgalileo.com](http://www.selexgalileo.com)

SELEXGALILEO\UK\Dsh-076\011001\mjg